

medical suction

vacuum regulators and collection systems



medical
technology for
patient care

nanovac

vacuum regulator

nanovac is a medical device used in hospital for the drainage of liquids, cardio thoracic surgery suction or the treatment of wounds. It regulates the level of depression provided by a network of medical vacuum. Nanovac connects to a wall vacuum source using a lockable probe or a mounting on rail. The vacuum regulator is the suction device. It must be associated with a collection jar and a suction pipe. It connects to wall gas outlets directly or indirectly with a claw and a mounting rail.

Products data

- ▶ Vacuum regulator adjustable in 3 dimensions (*3D patented system*)
 - 1 Rotating gauge for a reading in all directions
 - 2 Nipple and safety jar rotation to avoid tube clamping
 - 3 NF rotating gas probe **clac clac**
- ▶ Available in 0-250 mbar/hPa, 0-600 mbar/hPa and 0-1000 mbar/hPa versions
- ▶ Available with 100 ml safety jar sterilized at 134 ° C, with safety overflow systems and antibacterial filter.
 - Front filter on safety jar nipple
 - Quarter turn to unplug safety jar
 - Large front setting button
- ▶ On/Off side button to keep vacuum setting
- ▶ For NF version, dimensions are 220mm(H) x130mm(L) x80(l) mm and 480g weight(with NF probe and safety jar)
- ▶ Available with NF **clac clac** probe, DIN, SS or BS probes, single or double version as well as rail mounting.



nanovac

vacuum regulator

NF clic **clac** probe

nanovac is equipped with NF clic **clac** probe (patented) which allows a very simple installation with one hand, effortless.

Regulatory

- In accordance with the standard ISO 10079-3 for the suction devices
- Medical device of class IIa
- Device guaranteed two years
- Unitary marking of the device (traceability)

Use and maintenance advice

- Connect Nanovac to the vacuum network with the probe or the claw for rail mounting
- Obstruct the exit olive
- Press the green side button
- Slowly turn the large central setting button in counter clockwise (arrow sign above button) until reaching the desired vacuum level.
- Clean the outside of the device with water and SOAP. Rinse and dry. When using detergent products, verify their compatibility with plastics (ABS, polypropylene, polycarbonate). Ne pas immerger.
- Change the filter between each patient. The safety jar should be sterilized in the event of accidental liquid lift or perforated filter .
- The frequency of the function and sealing checks should be 1 to 3 years depending on the use.



nanovac

vacuum regulator

References

Right side, nanovac 0-1000 mbar rail mounted with BS inlet probe, anti bacterial filter, 1,5m hose, 1 liter collection jar and silicone connecting pipe.



SS vacuum probe

Reference	name			
with safety jar, inlet probe and anti bacterial filter				
11 001	Nanovac	0-250 mbar	AFNOR probe	safety jar
11 003	Nanovac	0-600 mbar	AFNOR probe	safety jar
11 005	Nanovac	0-1000 mbar	AFNOR probe	safety jar
11 701	Nanovac	0-250 mbar	DIN probe	safety jar
11 703	Nanovac	0-600 mbar	DIN probe	safety jar
11 705	Nanovac	0-1000 mbar	DIN probe	safety jar
11 801	Nanovac	0-250 mbar	BS probe	safety jar
11 803	Nanovac	0-600 mbar	BS probe	safety jar
11 805	Nanovac	0-1000 mbar	BS probe	safety jar
11 501	Nanovac	0-250 mbar	SS probe	safety jar
11 503	Nanovac	0-600 mbar	SS probe	safety jar
11 505	Nanovac	0-1000 mbar	SS probe	safety jar
Rail mounted, 1,5 m hose, safety jar, probe and universal clamp				
11 011	Nanovac	0-250 mbar	AFNOR rail mounting	safety jar
11 013	Nanovac	0-600 mbar	AFNOR rail mounting	safety jar
11 015	Nanovac	0-1000 mbar	AFNOR rail mounting	safety jar
11 711	Nanovac	0-250 mbar	DIN rail mounting	safety jar
11 713	Nanovac	0-600 mbar	DIN rail mounting	safety jar
11 715	Nanovac	0-1000 mbar	DIN rail mounting	safety jar
11 811	Nanovac	0-250 mbar	BS rail mounting	safety jar
11 813	Nanovac	0-600 mbar	BS rail mounting	safety jar
11 815	Nanovac	0-1000 mbar	BS rail mounting	safety jar
11 511	Nanovac	0-250 mbar	SS rail mounting	safety jar
11 513	Nanovac	0-600 mbar	SS rail mounting	safety jar
11 515	Nanovac	0-1000 mbar	SS rail mounting	safety jar

collection systems

collection jar, hose and pipe

Collection jar *Product data*

Three collection jar sizes are available in 1 liter, 2 liters and 4 liters

Each version can have a screw or pressure cap. The jars have clear graduations indicating the fluid level. There are reusable, sterilization versions are :

- 121°C in polycarbonate
- 134°C in polysulfone

Connections with the suction hose and suction device are with two smooth nipples on top of the cap. For security reasons, the cap is equipped with a mechanical overflow valve.

- PC or PS jar, polypropylene cap, safety trap and ball are in polypropylene, nitrile seal
- Dimensions and weight for 2 liters version are 300(H) x140(L) x135(W) mm and 550g
- Dimensions and weight for 4 liters version are 320(H) x190(L) x180(W) mm and 760g
- Inlet and outlet nipples are marked on cap (patient and vacuum)

Regulatory

- Conformity to the ISO 10079-3: 2014 norm suction vacuum systems.
- Class I medical device.
- Two year warranty

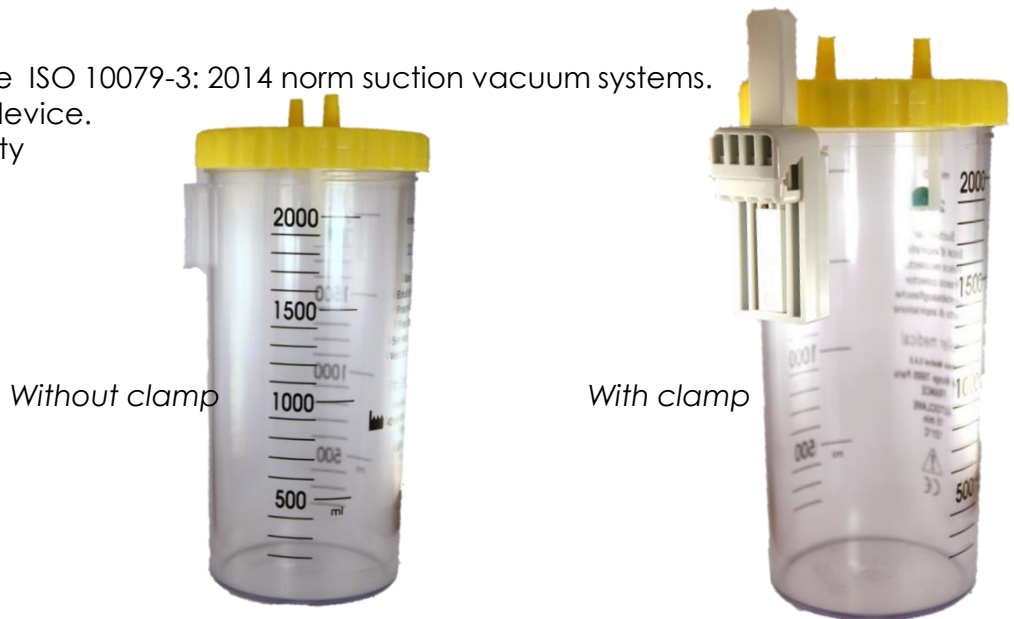

Collection jar (conformity to the ISO 10079-3: 2014 norm)

Reference	name
11100	1 liter jar, polysulfone with integrated moulded hanger and screwed cap
11101	1 liter jar, polysulfone with integrated moulded hanger and pressure-fit cap
11110	1 liter jar, polycarbonate with integrated moulded hanger and screwed cap
11111	1 liter jar, polycarbonate with integrated moulded hanger and pressure-fit cap
11200	2 liter jar, polysulfone with integrated moulded hanger and screwed cap
11201	2 liter jar, polysulfone with integrated moulded hanger and pressure-fit cap
11210	2 liter jar, polycarbonate with integrated moulded hanger and screwed cap
11211	2 liter jar, polycarbonate with integrated moulded hanger and pressure-fit cap
11411	4 liter jar, polycarbonate with integrated moulded hanger and pressure-fit cap
11401	4 liter jar, polysulfone with integrated moulded hanger and pressure-fit cap

silicone pipe

collection system, hose and pipe

Silicone pipe *Products data*

Autoclavable silicone translucent suction pipe packaged in rolls of 25 meters. They connect the collection systems and the vacuum regulators

Reference	Name
11915	Silicone pipe 6mm x 12 mm (internal diameter x external diameter)
11917	Silicone pipe 7mm x 13 mm (internal diameter x external diameter)
11920	Silicone pipe 8mm x 14 mm (internal diameter x external diameter)

Minimum order: 25m roll

Other sizes available, contact us

Regulatory

Material silicone elastomer
 Hardness 60 ± 5 Shore A according DIN 53 505
 Density 1.16 ± 0.03 g/cm³ according ISO 1183-1 A
 Color Translucid
 Breaking resistance
 8.0 N/mm² selon DIN 53 504-S1
 Lengthening Resistance allongement
 350 % according to DIN 53 504-S1
 Tearing resistance
 18.0 N/mm according to ASTM D624 B

Food certification FDA §177.2600 and BfR XV Silicone

Class I medical device CE marked

Temperature resistance up to 200°C (warm air)



Silicone pipe



hose pipe

collection system, hose and pipe

Low pressure hose *Products data*

Antistatic low pressure PVC hose, made of 4 extra-flexible layers, re-inforced with hard polyester fiber
Expiration date on angled body sticker.
Standards: AFNOR, BS, DIN and NIST

Contact us for other standard

Regulatory

- Conformity ISO 5359-2008, BS 5682, DIN 13260-2, NF S 90-116
- Class IIa medical device.
- Two year warranty
- 10 year life time



AFNOR Hose pipe
straight angled

Crimped hose pipe (conformity to ISO 5359 and NF S 90-116 norms)

name	length	AFNOR angled angled	AFNOR Straight angled	AFNOR Straight straight
		Reference		
Vacuum crimped hose pipe	1 m	6220	6320	6420
Vacuum crimped hose pipe	1,5 m	6221	6321	6421
Vacuum crimped hose pipe	2 m	6222	6322	6422
Vacuum crimped hose pipe	3 m	6223	6323	6423
Vacuum crimped hose pipe	4 m	6224	6324	6424
Vacuum crimped hose pipe	5 m	6225	6325	6425
Vacuum crimped hose pipe	7 m	6226	6326	6426

Crimped hose pipe (conformity to ISO 5359, BS 5682, DIN 13260-2)

name	length	NIST female straight straight	DIN Straight Angled	BS Straight Angled
		Reference		
Vacuum crimped hose pipe	1 m	6520	6820	6920
Vacuum crimped hose pipe	1,5 m	6521	6821	6921
Vacuum crimped hose pipe	2 m	6522	6822	6922
Vacuum crimped hose pipe	3 m	6523	6823	6923
Vacuum crimped hose pipe	4 m	6524	6824	6924
Vacuum crimped hose pipe	5 m	6525	6825	6925
Vacuum crimped hose pipe	7 m	6526	6826	6926



Company specialized in respiratory medicine and medical suction, **muller** medical uses medical technology to improve patient care. In hospitals with **nanotube**, **microflux** and **microbulle** (respiratory care and medical humidification), **nanovac** (medical suction), **gas terminal unit** and **gas hosepipe** (medical fluid networks), our devices treat respiratory diseases. They meet the requirements of the nursing staff and doctors and follow international medical standards.

contact

Muller Medical S.A.S (Head office)
42 rue Monge
75005 Paris, France

Muller Medical S.A.S (Laboratory)
54 rue Molière
94200 Ivry sur Seine, France

Tel.+33 (0) 1 76 28 00 26
Fax +33 (0) 1 46 72 43 06
info@muller-medical.com
www.muller-medical.com

Fluid medical networks AFNOR gas terminal unit



Medical
technology for
patient care

Fluid medical networks

AFNOR gas terminal unit

AFNOR gas terminal unit is for the use of medical gases to make safely quick connections and disconnections without the risk of mixing fluids

Products data

- Gas terminal units for vacuum and gas (O₂, N₂O, Air, CO₂) **single body**
- Dimensions 58(H) x60(L) x50(I) mm and 273g (with fixing plate)
- Maximum operating pressure 10 bar
- Normal operating pressure 4,5 bar +/- 0,5 bar (gas), 0 to -900 mbar (vacuum)
- Probe guide kit from Muller Medical are generic and **compatible with BM Air Liquide gas terminal units**



Bill of material

Parts	Material
1 Single body	Nickel-plated brass
2 Gas ball support	Brass
3 Probe guiding kit	Stainless steel
4 Valve ball	Stainless steel
5 Brazed connecting pipe	Copper
6 Fixing plate	Stainless steel

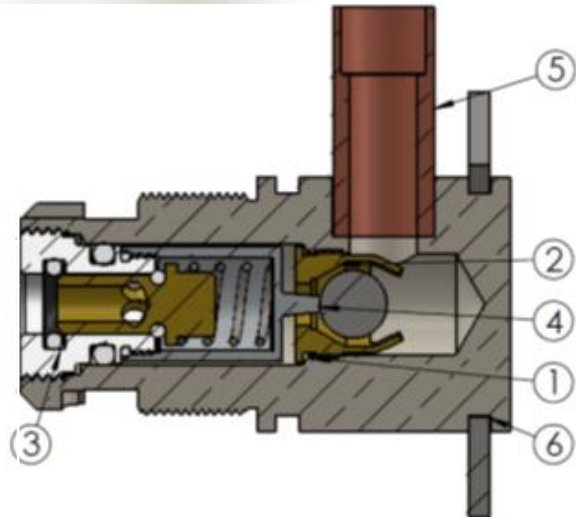

Conditioning

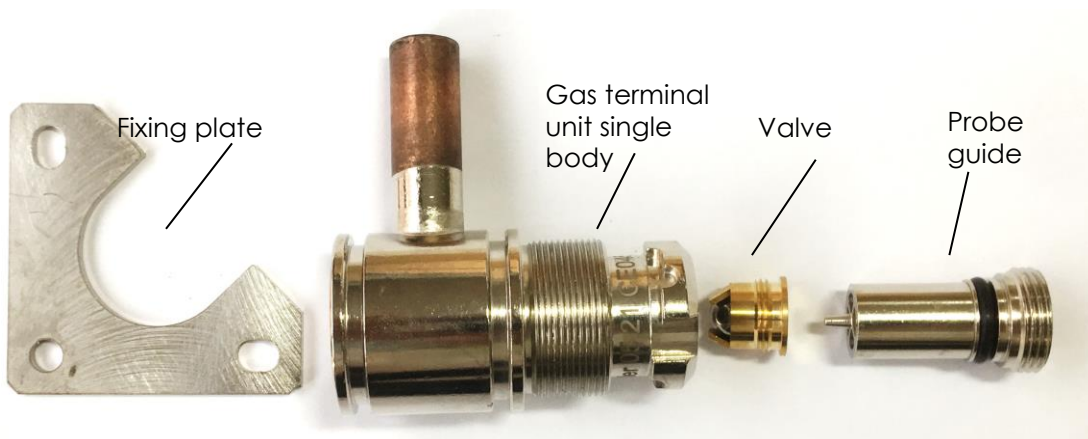

Fluid medical networks

AFNOR gas terminal units

Regulatory

- Conformity with NF S 90-116:2006 norm for gas outlets and related accessories for medical fluids
- IIa class medical device with CE marking **CE** 0459
- Engraved CE, company name, LOT week and year
- One year warranty

Material and nomenclature

	Part	Material
1	Box	ABS
2	Lid	Zamak
3	Terminal unit	Brass and SS
4	Bolt	Brass
5	Sticker	PVC

Different version

- Terminal units with fixing metal plate



References

Reference	Specification	
6150	O ₂ AFNOR terminal unit	12 mm dia copper pipe inlet with fixing metal plate
6151	Vac AFNOR terminal unit	12 mm dia copper pipe inlet with fixing metal plate
6152	Air 4 bar AFNOR terminal unit	12 mm dia copper pipe inlet with fixing metal plate
6153	N ₂ O AFNOR terminal unit	12 mm dia copper pipe inlet with fixing metal plate
6157	CO ₂ AFNOR terminal unit	12 mm dia copper pipe inlet with fixing metal plate
6158	Air 7 bar AFNOR terminal unit	12 mm dia copper pipe inlet with fixing metal plate

Fluid medical networks

AFNOR gas terminal unit

Different version

- Bulkhead with lid



- Box with lid



References

Reference	Specification	
6160	O ₂ AFNOR terminal unit	Gas terminal unit with box and lid
6161	Vac AFNOR terminal unit	Gas terminal unit with box and lid
6162	Air 4 bar AFNOR terminal unit	Gas terminal unit with box and lid
6163	N ₂ O AFNOR terminal unit	Gas terminal unit with box and lid
6167	CO ₂ AFNOR terminal unit	Gas terminal unit with box and lid
6168	Air 7 bar AFNOR terminal unit	Gas terminal unit with box and lid

Reference	Specification	
6180	O ₂ AFNOR terminal unit	Gas terminal unit bulkhead with lid
6181	Vac AFNOR terminal unit	Gas terminal unit bulkhead with lid
6182	Air 4 bar AFNOR terminal unit	Gas terminal unit bulkhead with lid
6183	N ₂ O AFNOR terminal unit	Gas terminal unit bulkhead with lid
6187	CO ₂ AFNOR terminal unit	Gas terminal unit bulkhead with lid
6188	Air 7 bar AFNOR terminal unit	Gas terminal unit bulkhead with lid

Fluid medical networks

Probe guide kit

Specification, user and maintenance information

- We propose two types of probe guide
 - Gas
 - Vacuum
- Gas probe guide filter is 60µm and vacuum probe guide filter is 300 µm
- Changing of probe guide can be implemented without closing vacuum or gas network (thanks to outlet valve)
- Probe guide change frequency depends upon use:
 - Critical care, operating and post-operating areas: once a year
 - Other department: one every other year
- Specific maintenance tools ref 61553 for gas, ref 61554 for vacuum
- Each maintenance operation either preventive or curative must be followed by the control of flows and leaks. Use only original parts, provided by Muller Medical.
- Muller Medical probe guide kits are compatible with Air Liquide BM gas terminal units.

Part	Material
1 Valve	Brass
2 Gas probe guide	Nickel plated brass
3 Probe O ring	Nitrile
4 Metal filter body	Brass
5 Probe guide O ring	Nitrile
6 Filter	Stainless steel
7 Valve O ring	Nitrile
8 Valve spring	Stainless steel

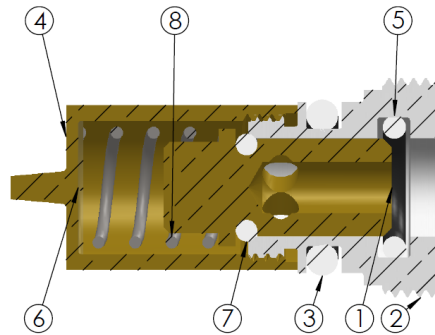

Gas probe guide



Vacuum probe guide



Probe guide kit references

Reference	Conditioning	Diameter	Thread	Fluid
61600	20 unit box	7 mm	M18x1,25 right	O ₂ , Air, CO ₂ , N ₂ O
61601	20 unit box	8 mm	M18x1 left	Vacuum
61608	20 unit box	6 mm	M18x1,5 left	Air 7 bar

Fluid medical networks

Flow splitter and duplex

Flow splitter

- The terminal unit splitter is designed to double the medical fluids outlets
- For quick connection/disconnection in all safety, without flow mixing of these fluids.
- Oxygen, air, vacuum and N2O version with AFNOR, DIN, BS probe

Duplex adapter

- Duplex adapter is designed to change medical fluids outlets standard from NIS to AFNOR for instance
- For quick connection/disconnection in all safety, without flow mixing of these fluids.
- Oxygen, air, vacuum and N2O version with AFNOR and NIST



BS oxygen flow splitter
REF 61952



AFNOR oxygen flow splitter
REF 6190



AFNOR NIST oxygen
adapter REF 61910

Flow splitter

Reference	Specification		
6190	Oxygen	Inlet AFNOR	outlet AFNOR
6191	Vacuum	Inlet AFNOR	outlet AFNOR
6192	Air	Inlet AFNOR	outlet AFNOR
61952	Oxygen	Inlet BS	outlet BS
61953	Vacuum	Inlet BS	outlet BS
61954	Air	Inlet BS	outlet BS
61852	Oxygen	Inlet DIN	outlet DIN
61853	Vacuum	Inlet DIN	outlet DIN
61854	Air	Inlet DIN	outlet DIN

Duplex adapter

61910	Oxygen	Inlet NIST	Outlet AFNOR
61911	Vacuum	Inlet NIST	Outlet AFNOR
61912	Air	Inlet NIST	Outlet AFNOR



Research and development is an important activity in Muller medical. The company is a medical technology start-up, which based its future on the development of innovative devices. She specializes in respiratory medicine for the treatment of chronic respiratory disease in patient home (chronic sleep disorders and COPD), the Hospital (respiratory care, medical humidification and fluid medical devices).

In its business, Muller Medical has the ambition to be the leader in innovation. Its R & D projects aim to remove technological locks in the field of materials and devices for respiratory care safety.

The company breaks new ground in the fight against bacterial proliferation, the disappearance of endocrine disrupters in the respiratory devices, additive manufacturing and inspired gas humidification

contact

Muller Medical S.A.S (head office)
42 rue Monge
75005 Paris, France

Muller Medical S.A.S (Laboratories)
54 rue Molière
94200 Ivry sur Seine, France

Tel.+33 (0) 1 76 28 00 26
Fax +33 (0) 1 46 72 43 06
info@muller-medical.com
www.muller-medical.com

muller medical

Medical technology for patient care

Oxygen therapy

Flowmeters and humidifiers



Medical
technology for
patient care

nanotube

Tube flow meter

nanotube is a ball flow meter for oxygen or medical air administration to insufficient respiratory patients. It uses the results of the company **research and development program**. It connects to wall gas terminal units directly with a probe or indirectly with rail mounting system.

Products data

- Pressure compensated flow meter (inlet pressure scale, insensitive to pressure variation down stream 0-1 l/min, 0-3 l/min, 0-7 l/min, 0-15 l/min, 0-30 l/min and 0-70 l/min oxygen and air versions)
- **Bisphenol A free (world premiere)**, bell and scales are in co polyester, robustness and clearness.
- Safety: **Sealed bell**, the unscrewing of the bell is impossible except in our labs
- 40µm inlet filter
- **Expanded scale** on 7, 15 l/min, 30 l/min and 70 l/min models: easiness of reading in lower part of the scale
- Body and knob nickel plated brass, robustness and accuracy.
- NF probe version, dimensions 165(H) x90(L) x30(W) mm and 289g
- M 9/16", M 1/4" or M 12x125 outlet for nipple or humidifier
- Available with Afnor, DIN, BS, Ohmeda or SS probes



Nanotube O₂ 15 l/min with BS probe (10912)

Regulatory

- Conformity with medical flow meter norm ISO 15002 and medical gas network ISO 7396-1, 400 kPa-0/+100kPa
- Class IIa medical device
- Two year warranty
- Lot number on each device(traceability)

nanotube

Tube flow meter

Use and maintenance advice

Set in vertical position , the flow meter knob opening is counter clockwise:

- The ball will show the flow (middle of the ball)
- The device can be cleaned with soapy water or hydro alcoholic solutions (check plastic compatibility in user manual)
- Do not plunge the device in liquid bath
- Two year warranty and ten year life time, the device must be checked every 1 to 3 years depending on use



Rail mounted nanotube with BS probe (10933)



Nanotube DIN probe (10812) with autoclavable humidifier (14492)

nanotube

Ball flowmeters

Selection of references

Other references are available, please consult us

Reference	Name and specification				
With Afnor, SS, DIN or BS probe					
10550	nanotube O ₂	1 l/min	4,5 bar	SS probe	9/16" M outlet
10400	nanotube O ₂	1 l/min	4,5 bar	Afnor probe	12x125 M outlet
10810	nanotube O ₂	1 l/min	4,5 bar	DIN probe	9/16" M outlet
10910	nanotube O ₂	1 l/min	4,5 bar	BS probe	9/16" M outlet
10551	nanotube O ₂	7 l/min	4,5 bar	SS probe	9/16" M outlet
10401	nanotube O ₂	7 l/min	4,5 bar	Afnor probe	12x125 M outlet
10811	nanotube O ₂	7 l/min	4,5 bar	DIN probe	9/16" M outlet
10911	nanotube O ₂	7 l/min	4,5 bar	BS probe	9/16" M outlet
10552	nanotube O ₂	15 l/min	4,5 bar	SS probe	9/16" M outlet
10402	nanotube O ₂	15 l/min	4,5 bar	Afnor probe	12x125 M outlet
10812	nanotube O ₂	15 l/min	4,5 bar	DIN probe	9/16" M outlet
10912	nanotube O ₂	15 l/min	4,5 bar	BS probe	9/16" M outlet
10553	nanotube O ₂	30 l/min	4,5 bar	SS probe	9/16" M outlet
10403	nanotube O ₂	30 l/min	4,5 bar	Afnor probe	12x125 M outlet
10813	nanotube O ₂	30 l/min	4,5 bar	DIN probe	9/16" M outlet
10913	nanotube O ₂	30 l/min	4,5 bar	BS probe	9/16" M outlet
10554	nanotube O ₂	70 l/min	4,5 bar	SS probe	9/16" M outlet
10404	nanotube O ₂	70 l/min	4,5 bar	Afnor probe	12x125 M outlet
10814	nanotube O ₂	70 l/min	4,5 bar	DIN probe	9/16" M outlet
10914	nanotube O ₂	70 l/min	4,5 bar	BS probe	9/16" M outlet
Rail mounted, 1,5 m hose pipe with probe					
10502	nanotube O ₂	15 l/min	4,5 bar	Afnor probe	12x125 M outlet
10832	nanotube O ₂	15 l/min	4,5 bar	DIN probe	9/16" M outlet
10932	nanotube O ₂	15 l/min	4,5 bar	BS probe	9/16" M outlet
Dual, flow switch					
10542	nanotube O ₂	15 l/min	4,5 bar	Afnor probe	12x125 M outlet
10552	nanotube O ₂	15 l/min	4,5 bar	Afnor probe	9/16 M outlet
10562	nanotube O ₂	15 l/min	4,5 bar	DIN probe	9/16" M outlet
10572	nanotube O ₂	15 l/min	4,5 bar	BS probe	9/16" M outlet



nanotube O₂ rail mounted with BS probe (10932) and humidifier (14492)



O₂ SS probe



Air SS probe

nanotube

Ball flow meter

nanotube twin has been designed to allow the treatment of two patient with one oxygen outlet with its double flowmeter. Nanotube twin connects to gas pipe outlet directly or indirectly with rail mounting system.

Products data

- Flowmeter with pressure compensation (scale at inlet pressure, insensitive to the change in pressure downstream)
- Versions 0-1 l/min, 0-7 l/min, 0-15 l/min, 0-30 l/min and 70 l/min oxygen and air
- **Bisphenol A free**, bell and scale are in co polyester, strength and clarity
- Safety: **bell sealed** the unscrewing of the Bell is impossible out of our Labs.
- Device inlet filter of 40µm
- **Expanded scale** on models 7, 15, 30 l/min and 70 l/min: made easier to read in the lower part of the scale
- Body and knob in satin nickel plated brass, strength and design.
- In BS probe version, dimensions are 165 mm(H) x130 mm(L) x95(l) mm and 595g
- Outlet 9/16", 1/4" or 12x125 for humidifier
- Available with Afnor probe DIN, BS, Ohmeda or UNI



Nanotube twin with flow AFNOR probe (10622)

Selected references

Other references are available consult us.

Double flowmeter with DIN or BS probes

Reference	Specification					
10952	nanotube twin	O ₂	15 l/min	4,5 bar	BS probe	12x125 M outlet
10953	nanotube twinl	O ₂	30 l/min	4,5 bar	BS probe	9/16'' M outlet
10852	nanotube twin	O ₂	15 l/min	4,5 bar	DIN probe	12x125 M outlet
10853	nanotube twinl	O ₂	30 l/min	4,5 bar	DIN probe	9/16'' M outlet

microflux

Compact flowmeter

Dial flowmeter for oxygen and medical air, **microflux** is very compact and easy to clean with its smooth surfaces and copper alloy body. Pediatric versions (from 0 to 1 l/min, from 0 to 5 l/min) and adult versions (from 0 to 15 l/min, 0 to 30 l/min, 0 to 50 l/min and 0 to 70 l/min) are available, with Afnor plug-in, DIN, BS, Ohmeda and UNI or rail-mounted.

Microflux with flow BS probe (12942) and humidifier (14492)

Products data

- Dial flowmeter
- 0-1 l/min, 0-5 l/min, 0-15 l/min and 0-30 l/min, 0-50 l/min and 0-70 l/min oxygen or air version
- Safety: flowmeter dismounting is impossible without specific tools.
- 10 flows available on every version
- 40µm inlet filter
- Regulation button with large windows for easier reading
- Nickel plated brass body, robustness and precision
- Version with NF plug-in, dimensions 95(h) x 65 (l) x 40(w) mm weight 356g
- Outlet M 9/16" M 1/4" or M 12x125 for olive, nipple or humidifier
- Available with Afnor, DIN, BS, Ohmeda or UNI probes

Regulatory

- Conformity to ISO 15002 norm for medical flowmeters and to ISO 7396-1, 400 kPa-0/+100kPa for medical gas networks
- Class IIa medical device
- Two year warranty
- Lot number on every flowmeter



microflux

Compact flowmeter

User advice and maintenance

Connect the device to a gas outlet and turn the button counter clock wise.

- Flow can be read in the front window
- For Cleaning and disinfection, use soapy water and rinse with clean water. Do not use abrasives. Disinfect with alcohol.
- Two year warranty with 10 year life expectancy, it must be checked from 1 to 3 years depending on use.



Microflux with flow BS probe
(12942)



microflux

Compact flowmeter

Selection of references

Other references are available, please consult us.



Microflux rail mounted with Afnor probe (12222)



Microflux twin with flow BS probe (12952) and humidifier (14492)

Double flowmeter with DIN or BS probes

Reference	Specification					
12952	microflux twin	O ₂	15 l/min	4,5 bar	BS probe	12x125 M outlet
12953	microflux twin	O ₂	30 l/min	4,5 bar	BS probe	9/16" M outlet
12852	microflux twin	O ₂	15 l/min	4,5 bar	DIN probe	12x125 M outlet
12853	microflux twin	O ₂	30 l/min	4,5 bar	DIN probe	9/16" M outlet

microflux

Compact flowmeter

Selection of references

Other references are available, please consult us.

Oxygen

Reference			Name		
12100	O ₂	1 l/min	4,5 bar	Afnor probe	Outlet M12x125
12170	O ₂	1 l/min	4,5 bar	DIN probe	Outlet M 9/16"
12970	O ₂	1 l/min	4,5 bar	BS probe	Outlet M 9/16"
12101	O ₂	5 l/min	4,5 bar	Afnor probe	Outlet M12x125
12171	O ₂	5 l/min	4,5 bar	DIN probe	Outlet M 9/16"
12971	O ₂	5 l/min	4,5 bar	BS probe	Outlet M 9/16"
12102	O ₂	15 l/min	4,5 bar	Afnor probe	Outlet M12x125
12172	O ₂	15 l/min	4,5 bar	DIN probe	Outlet M 9/16"
12972	O ₂	15 l/min	4,5 bar	BS probe	Outlet M 9/16"
12103	O ₂	30 l/min	4,5 bar	Afnor probe	Outlet M12x125
12173	O ₂	30 l/min	4,5 bar	DIN probe	Outlet M 9/16"
12973	O ₂	30 l/min	4,5 bar	BS probe	Outlet M 9/16"
12104	O ₂	50 l/min	4,5 bar	Afnor probe	Outlet M12x125
12174	O ₂	50 l/min	4,5 bar	DIN probe	Outlet M 9/16"
12974	O ₂	50 l/min	4,5 bar	BS probe	Outlet M 9/16"
12105	O ₂	70 l/min	4,5 bar	Afnor probe	Outlet M12x125
12175	O ₂	70 l/min	4,5 bar	DIN probe	Outlet M 9/16"
12975	O ₂	70 l/min	4,5 bar	BS probe	Outlet M 9/16"

Rail mounted, 1,5 m hose with plug Afnor

12220	O ₂	1 l/min	4,5 bar	Rail mounted1,5 m	Outlet M12x125
12221	O ₂	5 l/min	4,5 bar	Rail mounted1,5 m	Outlet M12x125
12222	O ₂	15 l/min	4,5 bar	Rail mounted1,5 m	Outlet M12x125
12223	O ₂	30 l/min	4,5 bar	Rail mounted1,5 m	Outlet M12x125
12224	O ₂	70 l/min	4,5 bar	Rail mounted1,5 m	Outlet M12x125

Air

12107	Air	15 l/min	4,5 bar	Afnor probe	Outlet M12x125
12177	Air	15 l/min	4,5 bar	DIN probe	Outlet M 9/16"
12977	Air	15 l/min	4,5 bar	BS probe	Outlet M 9/16"
12108	Air	30 l/min	4,5 bar	Afnor probe	Outlet M12x125
12178	Air	30 l/min	4,5 bar	DIN probe	Outlet M 9/16"
12978	Air	30 l/min	4,5 bar	BS probe	Outlet M 9/16"
12109	Air	50 l/min	4,5 bar	Afnor probe	Outlet M12x125
12179	Air	50 l/min	4,5 bar	DIN probe	Outlet M 9/16"
12979	Air	50 l/min	4,5 bar	BS probe	Outlet M 9/16"

microbulle humidifier

The microbulle humidifier is used in hospitals connected to a medical flowmeter or at patient home with oxygen concentrator, liquid oxygen tank or cylinder. It humidifies medical oxygen or medical air by micro bubbling in sterilized water filled jar.

The Aquapak pre filled bubble humidifier is available as well. Single use, 340 ml and 500 ml versions are proposed.

Products data

- Re usable humidifier more economical than single use humidifier
- 200 ml version in polysulfone sterilized at 134°C, polycarbonate version at 121 °C
- For gas humidification, diffusion through micro porous polyethylene foam
- Connection and axis are in nickel plated brass, cap in polypropylene, hose in silicone, nitrile o-ring
- Dimensions 130(H) x90(L) x60(l) mm and 80g
- Connection thread is F 9/16'' or F 12x125 for flowmeter or oxygen generator
- Maximum inlet pressure is 500 kPa
- 8 ml water humidification per hour at 10 l/min flow



Microbulle auto clavable bubble humidifier



Nanotube with medical humidifier



Aquapak pre filled humidifier 340 ml

Regulatory

- Conformity with ISO 8185 for medical humidifier
- Class IIa device
- Two years warranty

Oxygen accessories

Hose and pipe

Hoses are antistatic PVC, with reinforced thickness and extra-soft. They allow to extend the vacuum, air or oxygen supply from a gas supply to a respiratory support device. Their straight fittings or T shape are in conformity with AFNOR, DIN, BS or NIST norms (other standards upon request). Several lengths are available (1.5, 3 and 5 meters).

Hose pipe (conformity with ISO 5359-2008) Life duration 10 years

Designation	length	Straight angled M BS	Straight angled M AFNOR	Straight angled M DIN	Straight straight F NIST
		Reference			
O ₂ crimped hose pipe	1 m	6900	6300	6800	6500
O ₂ crimped hose pipe	1,5 m	6901	6301	6801	6501
O ₂ crimped hose pipe	2 m	6902	6302	6802	6502
O ₂ crimped hose pipe	3 m	6903	6303	6803	6503
O ₂ crimped hose pipe	4 m	6904	6304	6804	6504
O ₂ crimped hose pipe	5 m	6905	6305	6805	6505

Designation	length	angled angled	Straight angled	Straight straight	Straight straight F NIST
		Reference			
Air crimped hose pipe	1 m	6940	6340	6840	6540
Air crimped hose pipe	1,5 m	6941	6341	6841	6541
Air crimped hose pipe	2 m	6942	6342	6842	6542
Air crimped hose pipe	3 m	6943	6343	6843	6543
Air crimped hose pipe	4 m	6944	6344	6844	6544
Air crimped hose pipe	5 m	6945	6345	6845	6545



NIST DIN oxygen hose pipe



AFNOR hose pipe

Oxygen accessories

Direct probes and duplex adaptor

Accessories

Direct probe

- Used to connect directly medical device to terminal unit
- Straight or angled, nipple or threaded outlet (M12x125 or 9/16")



Direct probe with nipple

Duplex adapter

- The terminal unit duplex adapter is designed to double the medical fluids outlets
- For quick connection/disconnection in all safety, without flow mixing of these fluids.
- Oxygen, air, vacuum and N₂O version with Afnor, DIN, BS probe



BS oxygen flow splitter

Direct probe BS

Reference	Specification		
6985	Inlet BS	Outlet nipple 6/11	Oxygen
6986	Inlet BS	Outlet nipple 6/11	Vacuum
6987	Inlet BS	Outlet nipple 6/11	Oxygen
6688	Inlet BS	Outlet nipple 6/11	N ₂ O

Flow splitter BS

Reference	Specification		
6190	Oxygen	Inlet Afnor	outlet Afnor
6191	Vacuum	Inlet Afnor	outlet Afnor
6192	Air	Inlet Afnor	outlet Afnor
61952	Oxygen	Inlet BS	outlet BS
61953	Vacuum	Inlet BS	outlet BS
61954	Air	Inlet BS	outlet BS



Afnor oxygen flow splitter

High flux oxygen

Flowmeters

High-flow oxygen therapy is non-invasive respiratory support that delivers warmed, humidified, oxygen-enriched air to patients. It can provide respiratory support for patients with acute hypoxemic respiratory failure and can also prevent subsequent intubation. It leads to improvements in oxygenation, respiratory rate and patient comfort. This oxygen therapy is also economical, as it does not require a ventilator, and can be used across different hospital departments.



Selection of references

Other references are available, please consult us.

10403	nanotube	O ₂	30 l/min	4,5 bar	Afnor probe	12x125 M outlet
10813	nanotube	O ₂	30 l/min	4,5 bar	DIN probe	9/16" M outlet
10913	nanotube	O ₂	30 l/min	4,5 bar	BS probe	9/16" M outlet
10404	nanotube	O ₂	70 l/min	4,5 bar	Afnor probe	12x125 M outlet
10814	nanotube	O ₂	70 l/min	4,5 bar	DIN probe	9/16" M outlet
10914	nanotube	O ₂	70 l/min	4,5 bar	BS probe	9/16" M outlet
12104	microflux	O ₂	50 l/min	4,5 bar	Afnor probe	Outlet M12x125
12174	microflux	O ₂	50 l/min	4,5 bar	DIN probe	Outlet M 9/16"
12974	microflux	O ₂	50 l/min	4,5 bar	BS probe	Outlet M 9/16"
12105	microflux	O ₂	70 l/min	4,5 bar	Afnor probe	Outlet M12x125
12175	microflux	O ₂	70 l/min	4,5 bar	DIN probe	Outlet M 9/16"
12975	microflux	O ₂	70 l/min	4,5 bar	BS probe	Outlet M 9/16"



Company specialized in respiratory medicine and medical suction, **muller** medical uses medical technology to improve patient care. In hospitals with **nanotube**, **microflux** and **microbulle** (respiratory care and medical humidification), **nanovac** (medical suction), **gas terminal unit** and **gas hosepipe** (medical fluid networks), our devices treat respiratory diseases. They meet the requirements of the nursing staff and doctors and follow international medical standards.

contact

Muller Medical S.A.S (Head office)
42 rue Monge
75005 Paris, France

Muller Medical S.A.S (Laboratories)
54 rue Molière
94200 Ivry sur Seine, France

Tel.+33 (0) 1 76 28 00 26
Fax +33 (0) 1 46 72 43 06
info@muller-medical.com
www.muller-medical.com